



BS5163 Rising Stem Cast Iron Gate Valve (Metal Seal)

BS5163 Rising Stem Cast Iron Gate Valve (Metal Seal)



Figure: Z41032
 Size : 2"-12"
 Design Standard : BS5163
 Face to Face : BS5163
 Flange Drilling : BS4504 PN16

Application

Working Temp: 100 °C
 Working Pressure: PN10 or PN16
 Suitable Media: Water, Steam, Oil, ect.
 Not recommended for Steam Service.

Caution FREEZING WEATHER PRECAUTION - Subsequent to testing a piping system, gate valves should be left in an open position to allow complete drainage.

Specification

Bolted Bonnet; Outside Screw & Yoke
 Rising Stem; Solid Wedge
 Design Standard: BS5163
 Face to Face: BS5163

Materials

No	Part Name	Materials	
1	Body	ASTM A126A(B)	GG20 GG25
2	Seat Ring	ASTM B36/B62, SS410	Brass, Bronze
3	Wedge Ring	ASTM B36	Brass
4	Wedge	ASTM A126A(B)	GG20 GG25
5	Bolt	A216 WCB	GS-C25
6	Nut	A216 WCB	GS-C25
7	Washer	A216 WCB	GS-C25
8	Bonnet Gasket	Graphite	Graphite
9	Packing	Graphite	Graphite
10	Bolt	A216 WCB	GS-C25
11	Gland	ASTM A126A(B)	GG20 GG25
12	Washer	A216 WCB	GS-C25
13	Nut	A216 WCB	GS-C25
14	Bonnet	ASTM A126A(B)	GG20 GG25
15	Yoke Nut	ASTM B36	Brass
16	Nut	A216 WCB	GS-C25
17	Hand wheel	ASTM A126B	GG25
18	Stem	SS410	X10Cr13

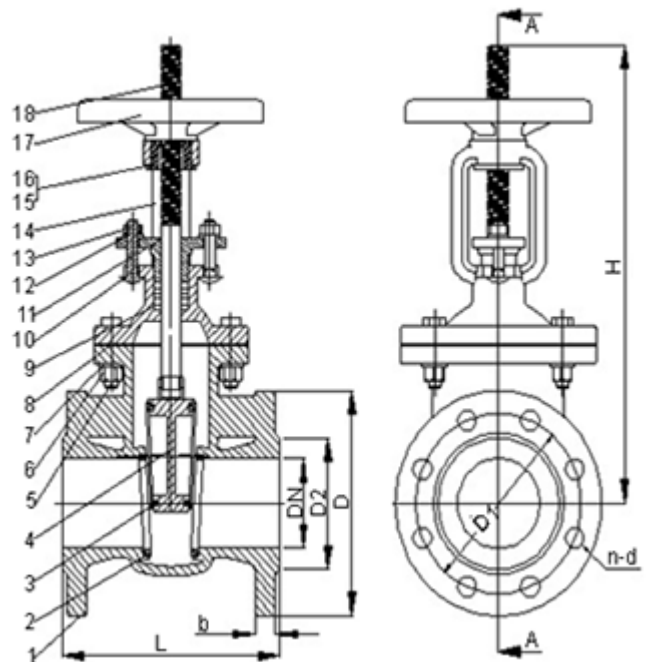



BS5163 Rising Stem
Cast Iron Gate Valve
(Metal Seal)

BS5163 Rising Stem Cast Iron Gate Valve (Metal Seal)

Dimensions(BS4504 PN16 Flange drilling)

DN	D	D1	D2	L	H	b	n	d
50	165	125	99	178	330	17	4	19
65	185	145	118	190	385	17	4	19
80	200	160	132	203	420	19	8	19
100	220	180	156	229	500	21	8	19
125	250	210	184	254	660	23	8	19
150	285	240	211	267	740	23	8	23
200	340	295	266	292	930	27	12	23
250	405	355	319	330	1130	29	12	28
300	460	410	370	356	1330	29	12	28