



# BS5163 Non-Rising Stem Cast Iron Gate Valve(Metal Seal)

## BS5163 Non-Rising Stem Cast Iron Gate Valve(Metal Seal)



Figure: Z45032  
 Size : 2"-12"  
 Design Standard : BS5123  
 Face to Face : BS5163  
 Flange Drilling : BS4504

### Application

Working Temp: 100 °C  
 Working Pressure: PN10 or PN16  
 Suitable Media: Water, Steam, Oil, ect.  
 Not recommended for Steam Service.

### Specification

Design Standard: BS5163  
 Face to Face: BS5163  
 Testing Conform to BS6755

**Caution:** FREEZING WEATHER PRECAUTION - Subsequent to testing a piping system, gate valves should be left in an open position to allow complete drainage.

### Materials

No	Part Name	Material	
1	Body	ASTM A126A(B)	GG20 GG25
2	Seat Ring	ASTM B36/B62,SS410	Brass, Bronze
3	Wedge Ring	ASTM B36	Brass
4	Wedge	ASTM A126A(B)	GG20 GG25
5	Wedge Nut	ASTM B36	Brass
6	Bolt	A216 WCB	GS-C25
7	Nut	A216 WCB	GS-C25
8	Washer	A216 WCB	GS-C25
9	Bonnet Gasket	Graphite	Graphite
10	Nut	ASTM B36	Brass
11	Half Ring	A216 WCB	GS-C25
12	Packing	Graphite	Graphite
13	Bonnet	ASTM A126A(B)	GG20 GG25
14	Gland	ASTM B36	Brass
15	Stem	SS410	X10Cr13
16	Hand wheel	ASTM A126B	GG25
17	Washer	A216 WCB	GS-C25
18	Bolt	A216 WCB	GS-C25

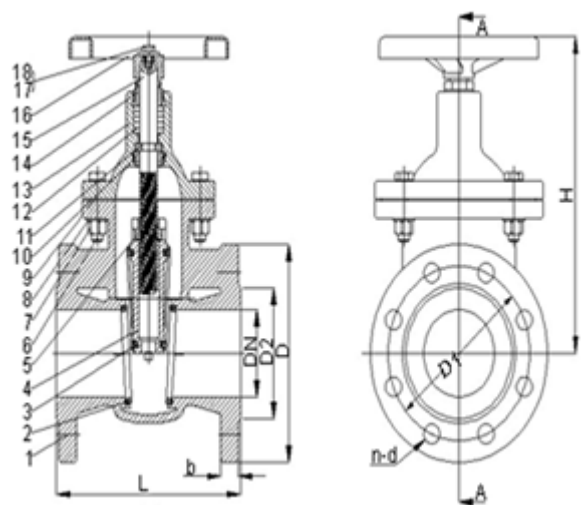



BS5163 Non-Rising  
Stem Cast Iron  
Gate Valve(Metal Seal)

BS5163 Non-Rising Stem Cast Iron Gate Valve(Metal Seal)

Dimensions(BS4504 PN16 Flange drilling)

DN	D	D1	L	H	b	n	d
50	165	125	178	250	17	4	18
65	185	145	190	265	17	4	18
80	200	160	203	300	19	8	18
100	220	180	229	350	21	8	18
125	250	210	254	410	23	8	18
150	285	240	267	450	23	8	22
200	340	295	292	550	27	12	22
250	405	355	330	650	29	12	26
300	460	410	356	710	29	12	26