

900X Emergency Shut-off Valve

Product introduction

900X emergency shut-off valve is used in parallel system of fire protection water and drinking water to change the water supply direction. When fire disaster incurs, need much water to remove the fire, 900X emergency shut-off valve at once shut off the drinking water to supply enough water to fire protection; when fire protection do not need water and the pressure decreases, the valve opens automatically and keep normally open to assure drinking water supplying. The system does not need special fire protection pipe net due to this kind of valve, so decrease construction cost and save water much. It's sensibility is very high and it is very reliable and it is easy to maintain the valve and it's working life is very long.

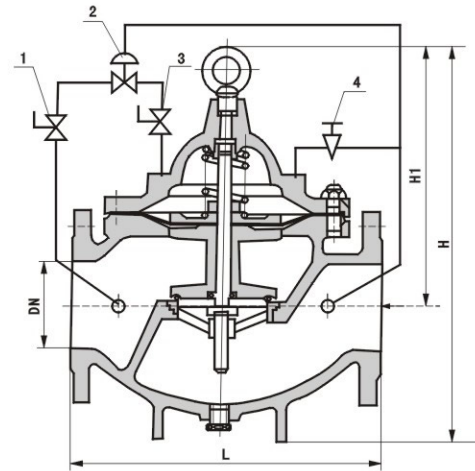

1 little ball valve 2 pilot valve 3 little ball valve 4 little valve

Installation diagr

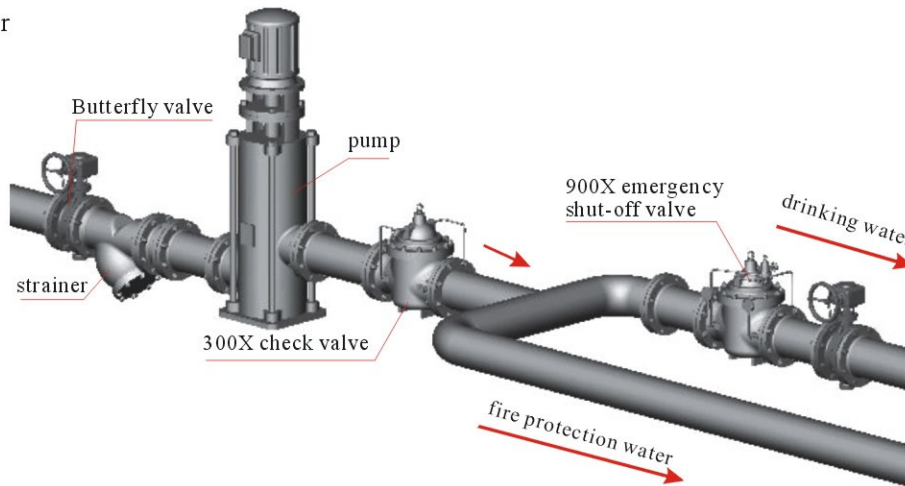

Unit: mm

| Main dimension | DN | 20 | 25 | 32 | 40 | 50 | 65 | 80 | 100 | 125 | 150 | 200 | 250 | 300 | 350 | 400 | 450 |
|----------------|----|-----|-----|-----|-----|-----|-----|-----|-----|-----|-----|-----|-----|-----|-----|-----|-----|
| L | | 150 | 160 | 180 | 200 | 203 | 216 | 241 | 292 | 330 | 356 | 495 | 622 | 698 | 787 | 914 | 978 |
| H ₁ | | 247 | 247 | 247 | 278 | 278 | 298 | 313 | 350 | 365 | 420 | 450 | 470 | 490 | 526 | 570 | 570 |
| H | | 342 | 342 | 342 | 395 | 395 | 405 | 430 | 510 | 560 | 585 | 675 | 730 | 760 | 840 | 910 | 910 |