

# 700X Pump Control Valve

**Product introduction**

700X pump control valve is installed at the pump's outlet in high building and other feeding system to prevent fluid flowing backwards. Before the pump will stop, the valve closes 90% or so ahead to prevent water-hammering and water-hitting at pump's instant stop; after the pump fully stop, the valve close fully to prevent the fluid flowing backwards at the outlet of the pump to protect the pump and prevent the pump turn backwards due to backward fluid. It is necessary protection equipment for pump. It is flow-line designed and it can open or close according to electric-magnetic valve's pilot. It is safe to use and it can effectively prevent water-hammering and water-hitting. It's life is very long and it is easy to install and to maintain this kind of valve.

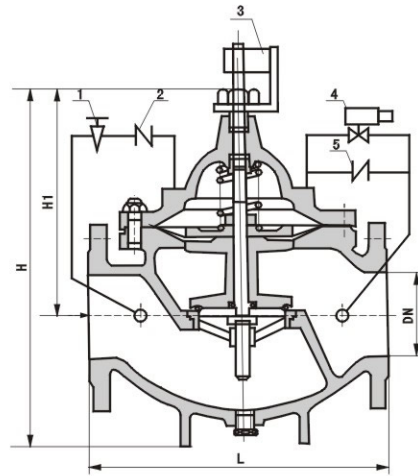

1, needle valve 2 check valve 3 stroke switch  
4 electric-magnetic valve 4 check valve

**Installation diagram**

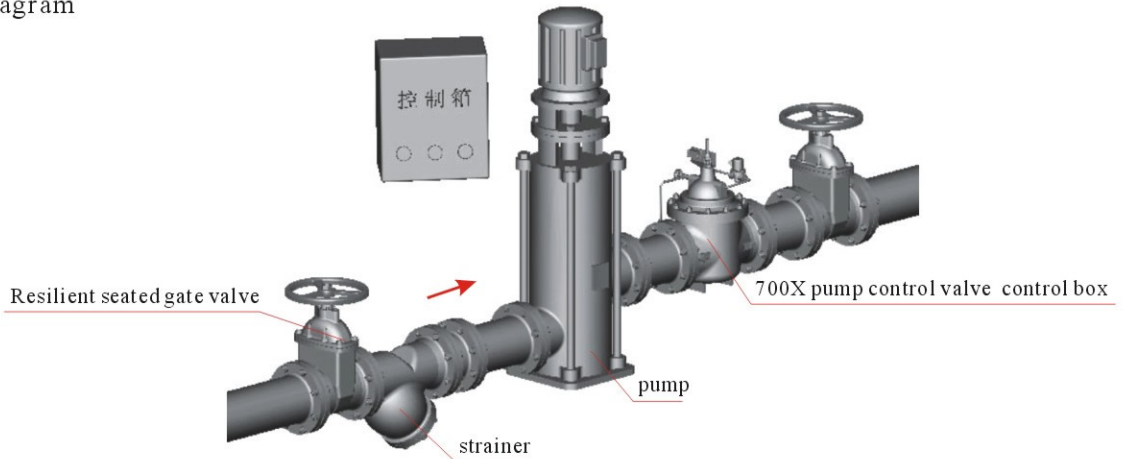

Main dimension	DN	Unit: mm											
		50	65	80	100	125	150	200	250	300	350	400	450
L	203	216	241	292	330	356	495	622	698	787	914	978	
H <sub>1</sub>	160	180	200	270	310	320	370	430	480	525	580	635	
H	395	405	430	510	560	585	675	730	760	840	910	910	