

500X pressure relief or sustaining valve

Product introduction 500X pressure relieving/sustaining valve is used in fire protection or other feeding system to prevent overpressure of system or to maintain the needed pressure in fire protection. It can weaken water-hammering after fire pump stops. It is used in water-hammering elimination equipment in large-scale feeding system. There is one piece of self-cleaning mesh installed at the inlet of the valve's control system to assure the system run without any block. System runs stably and it's strength is very high and it's life is very long. It is suitable for DN600mm or less pipeline.

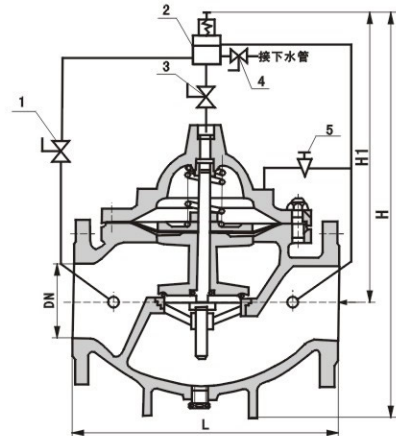

1 little ball valve 2 pilot valve 3 little ball valve 4 little valve 5 needle valve

Installation diagram

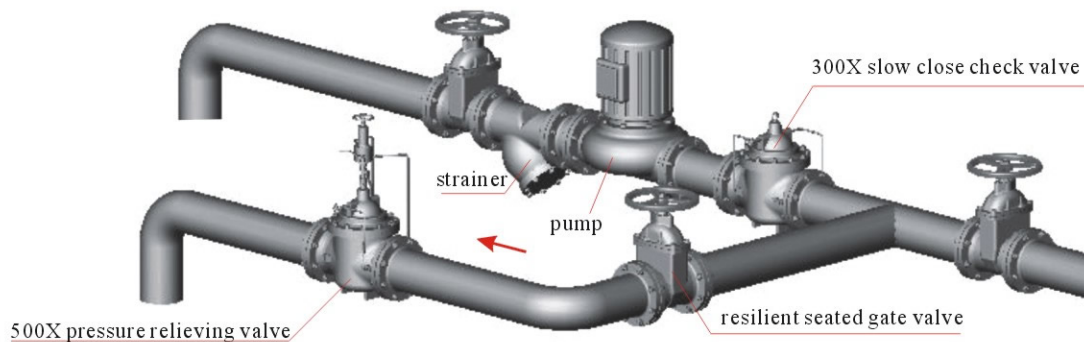

unit: mm

Main dimension	DN	20	25	32	40	50	65	80	100	125	150	200	250	300	350	400	450
L		150	160	180	200	203	216	241	292	330	356	495	622	698	787	914	978
H ₁		463	463	463	516	516	520	537	596	653	709	805	855	953	990	1030	1030
H		557	557	557	610	610	625	642	750	808	864	1135	1185	1325	1385	1445	1445