

100X remote control float valve

Product introduction 100X diaphragm type remote control float valve has many kinds of function and is installed at the inlet of pool or water tower, when the water-level reach the setting level, the main valve closes by the float pilot valve's control and stop supplying water; when the water-level comes down, the main valve opens by the float pilot valve's control and supply water to the pool. 100X remote control float valve can control the water-level of pool precisely and is not interrupted by the pressure. 100X remote control float valve can be installed freely according to the height of pool and using space. It is easy to maintain , to commission and to inspect. This kind of valve is reliable on sealing and it's life is very long. Diaphragm type valve is reliable and it's strength is high and it moves quickly and it is suitable for pipeline DN450mm or less. For DN500mm or more , piston type valve is advised to be chosen.

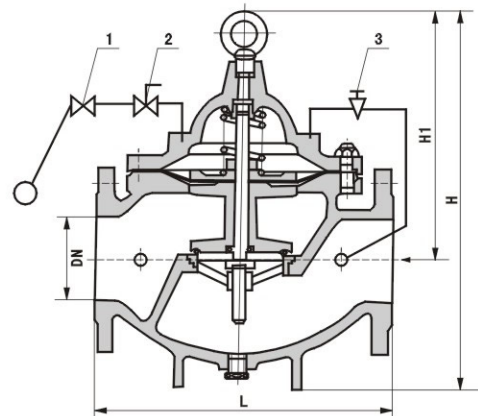

1, float pilot valve 2 ball valve 3 needle valve

Installation diagram

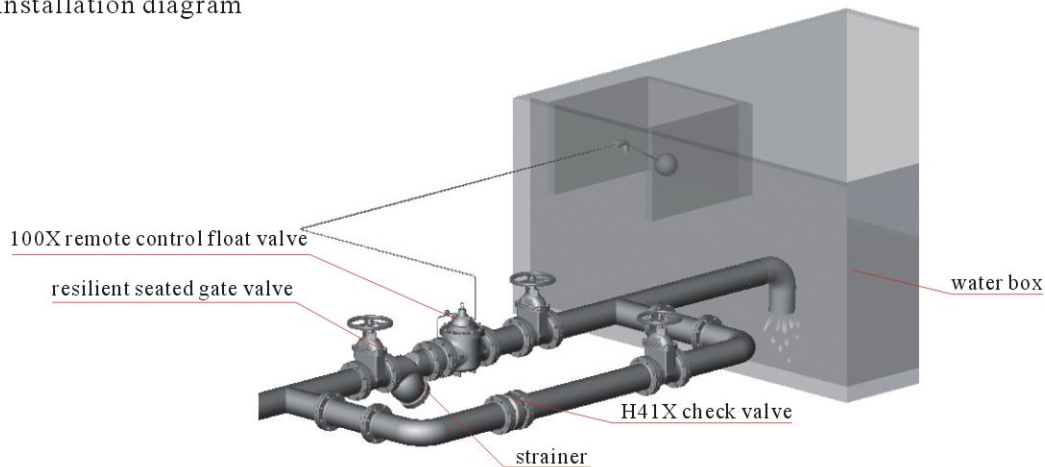

unit: mm

Main dimension	DN	20	25	32	40	50	65	80	100	125	150	200	250	300	350	400	450
L		150	160	180	200	203	216	241	292	330	356	495	622	698	787	914	978
H ₁		179	179	179	210	210	215	245	305	365	415	510	560	658	696	735	735
H		212	212	212	265	265	310	350	460	520	570	840	890	1030	1090	1150	1150